

(No Model.)

W. S. RALYA.
SAW TOOL.

No. 438,180.

Patented Oct. 14, 1890.

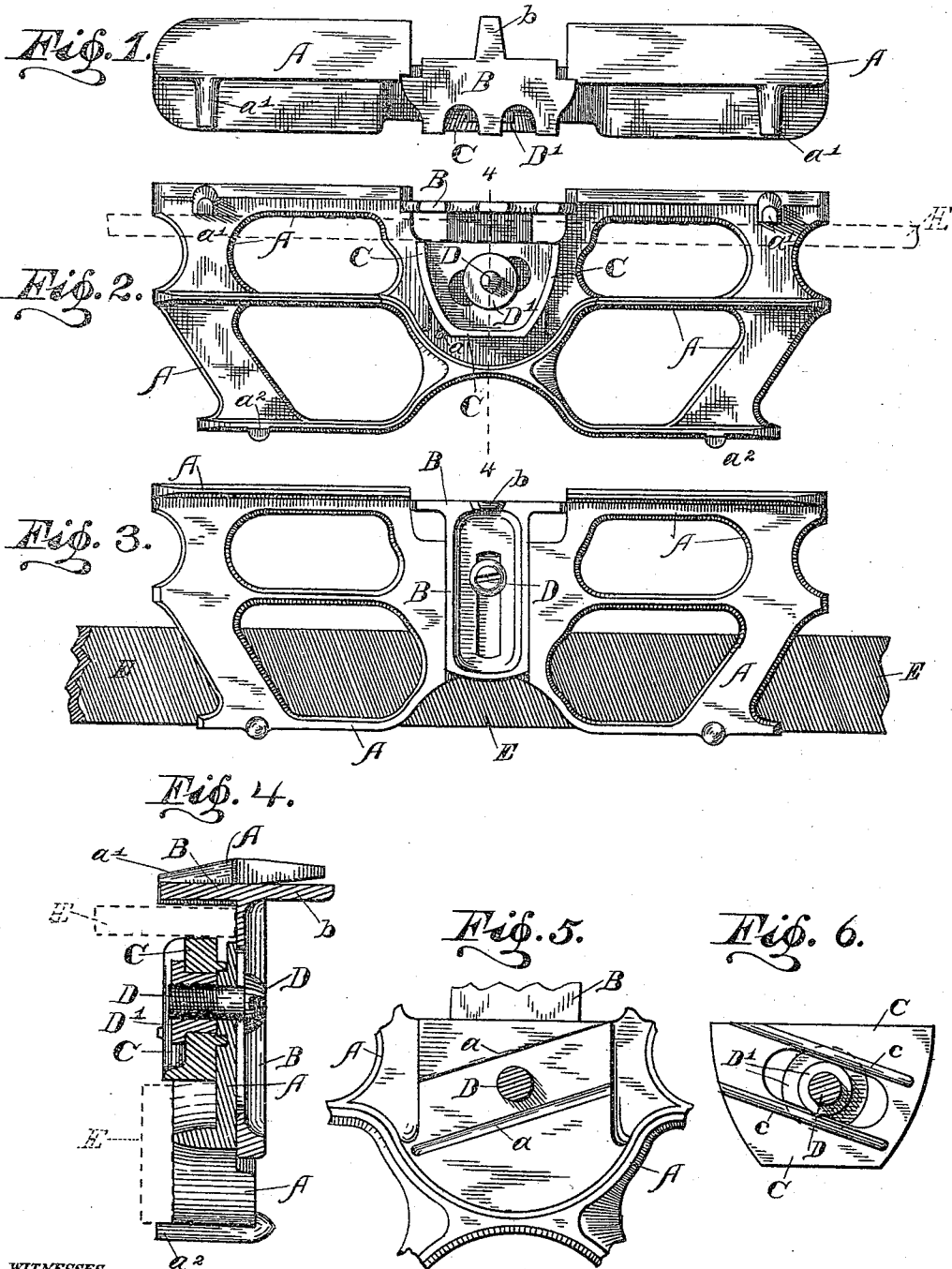

WITNESSES.

Edw. Dean Rhodes.
James Walsh.

INVENTOR.
William S. Ralya,
per E. W. Bradford.
ATTORNEYS.

UNITED STATES PATENT OFFICE.

WILLIAM S. RALYA, OF INDIANAPOLIS, INDIANA, ASSIGNOR TO THE E. C. ATKINS & COMPANY, OF SAME PLACE.

SAW-TOOL.

SPECIFICATION forming part of Letters Patent No. 438,180, dated October 14, 1890.

Application filed December 7, 1889. Serial No. 332,953. (No model.)

To all whom it may concern:

Be it known that I, WILLIAM S. RALYA, a citizen of the United States, residing at Indianapolis, in the county of Marion and State of Indiana, have invented certain new and useful Improvements in Saw-Tools, of which the following is a specification.

My present invention consists in certain improvements upon that for which Letters Patent No. 385,006 were granted upon my petition, and dated June 26, 1888, whereby the device shown in said Letters Patent is provided with an improved form of locking device and with an improved gage for the clearing-teeth, as will be hereinafter more particularly described and claimed.

Referring to the accompanying drawings, which are made a part hereof, and on which similar letters of reference indicate similar parts, Figure 1 is a top or plan view of a tool embodying my said improvements; Fig. 2, a front elevation of the same; Fig. 3, a rear elevation; Fig. 4, a transverse vertical sectional view looking toward the left from the dotted line 4 4 in Fig. 2; Fig. 5, a detail view of that portion of the frame which receives the locking device, said locking device being removed; and Fig. 6, a rear elevation of said locking device.

In said drawings the portions marked A represent the frame of the device; B, the clearing-tooth gage; C, the locking device; D, a screw or bolt whereby the parts are held together, and E the file.

The frame A is substantially identical with the frame shown in my aforementioned Letters Patent, except that it is provided with diagonal grooves or ribs *a* at the point where the locking device C rests against it, with which corresponding diagonal ribs or grooves on said locking device will engage, whereby said locking device is guided in its movement, as shown most plainly in Figs. 5 and 6. It has the projections *a'* and *a''*, which serve as bearing-surfaces against which one edge or one side of the file will rest when it is secured in the frame, and flanges which rest against the surface of the saw during the various manipulations of the device.

The clearing-tooth gage B is mounted in a groove or way in the frame A, is provided with a

slot and secured in place by means of the screw or bolt D, and is generally similar to that shown in said aforementioned Letters Patent, except that it has a narrow tongue or projection *b*, which extends out between the two prongs of the clearing-tooth when the device is in use, and which tongue or projection serves to support the file as it passes over the points of said clearing-tooth and hold it squarely to its work, thus insuring that said points shall be trimmed off squarely instead of at an angle, as might otherwise happen, especially with careless or unskillful workmen.

The locking device C is a different form of cam from that shown in the aforementioned Letters Patent, being practically two wedges secured together at their ends, or, in other words, a plate having a central diagonal slot which gives each of its two sides a wedge formation. The slot passes over a stud which may be either formed on the frame A or be a part of the nut into which the screw D enters, and a head or collar on said stud, or in the form of a nut to said screw or bolt, holds said locking device in position. I prefer to make said stud and said head or nut and collar in one piece and separate from the frame, as shown and as will be presently described. This locking device preferably has one or more ribs *c* or grooves, (two are shown,) which engage with corresponding grooves *a* or ribs on the face of the frame A, and this locking device is thereby guided in its movement, said ribs and grooves serving as ways or tracks whereby the direction or movement of said locking device is determined, they being parallel with the slot in said locking device. These grooves and ribs can be omitted without departing from my invention; but I find their use of considerable service in keeping the locking device always in proper position, as it would otherwise turn upon the stud which passes through its slot and would need to be adjusted by hand before locking the file thereby.

The screw or bolt D passes through the clearing-tooth gage B, the frame A, and the locking device C and enters the combined stud and nut D' and holds all of said parts to proper position. The neck of said stud and nut D', which passes through the slot in the locking device C, is long enough so that said

combined stud and nut can be drawn firmly against the face of the frame A, and thus lock said parts A and D' rigidly together without interfering with the movement of the locking device C, which moves diagonally over the neck of said combined stud and nut, and is held from falling away from position by the flange or collar thereon.

The file E may be any usual or ordinary file adapted for the purpose. When it is used to joint the ends of the points of the teeth, it is located as indicated by the dotted lines in Fig. 2, and when it is used to joint the sides of the points of the teeth it is located as shown in Fig. 3. Both positions are shown by dotted lines in Fig. 4.

Having thus fully described my said invention, what I claim as new, and desire to secure by Letters Patent, is—

1. The combination, in a saw-tool, of the frame A, having appropriate rests for one side of a jointing-file, and a locking device C in the form of a plate having a diagonal slot, whereby by moving said locking device said file will be clamped firmly in position, substantially as shown and described.

2. The combination, with the frame and file of a saw-jointer, of a locking device in the form of a double wedge or a plate having a

diagonal slot, substantially as shown and described.

3. The combination, in a saw-tool, of the frame having flanges or projections against which a file may rest, and a clamp portion adapted to move longitudinally of said frame on a stud or projection thereon or secured thereto, said clamp portion having an inclined slot which passes over said stud or projecting part, whereby when it is moved its edges are caused to approach or recede from the file when said file is in place.

4. The combination, in a saw-tool, with the frame and file thereof, of a locking device resting against the face of the frame and provided with diagonal ribs or grooves, the face of said frame being also provided with corresponding grooves or ribs which engage therewith, whereby said locking device is guided in a diagonal direction across the face of said frame as it is moved, substantially as set forth.

In witness whereof I have hereunto set my hand and seal, at Indianapolis, Indiana, this 4th day of December, A. D. 1889.

WILLIAM S. RALYA. [L. S.]

Witnesses:

CHESTER BRADFORD,
JAMES WALSH.